

Nesting Chair: Twenty2 & Eighteen5

Disassembly Instructions

The *Twenty2* (22" wide seat) and the *Eighteen5* (18.5" wide seat) nesting chairs are available with various component options. Disassembly will vary depending on the component characteristics of each individual chair. The component options relevant to these chairs are: chair arms, upholstered or hard seat components, caster or glide fitted feet.

Weights based on *Twenty2* chair shown below.

Recyclable Material (lbs)

steel frame	12.00
steel fastening bracket (1pcs)	1.00
foam	0.25

Total Weight 33.25



Twenty2 - nesting chair

Tools: Phillips head, Robertson screwdriver, box cutter knife, hammer or rubber mallet, flat headed screwdriver or similar wedge shaped tool.

Skill Set: Good manual dexterity.

Estimated Time: 20min (per chair. w/ max options)

Steps:

1. Seat - 2min

Flip the chair seat to the upright position in order to access the under side of the seat. Locate the 12 fastener heads (Phillips head type). Unscrew all fasteners. Detach and separate the top portion of the seat (seating surface) from the seat assembly.

Return the seat to the down position. Locate the two fastening brackets at the rear of the seat. Unthread fastening screws and remove the top portion of the bracket assembly. *Caution: seat will no longer be attached to the frame and may become free resulting in the seat falling.*

Remove the remaining seat component from frame. To do so, flip the seat to the upright position, then lift upward out of the frame.

Separate the remaining fastening bracket components from the seat. To do so, unclip the bracket component from the seat pan.

2. Back - 2min

With a hammer or rubber mallet, tap or hit the underside of the back close to the chair frame and back connection points. Alternate hits between either ends of back rest till the back and frame are separated.

3. Armrest - 2min

Place the chair frame on its side. Secure frame to prevent movement. With a rubber mallet or hammer, hit the underside of the arm rest nearest to the corner radius of the arm. Continue to hit until the armrest is separated from the frame. This process may require some force. Flip the chair to the opposing side and repeat the process. *Caution: sharp elements of the frame may be exposed once separate from arms. Handle with care.*

4. i. Glides - 4min

With a flat headed screwdriver or similar tool, place the wedge of the object between the connection of the glide and frame. While applying inward force, pry the glide from the frame. This may require the use of a hammer or rubber mallet. Repeat process to all four feet.

5. ii. Casters - 4min

Flip the chair frame up side down (feet up) to access casters. Remove casters by pulling upward, separating casters from socket fitting. If the caster does not separate freely, a flat bladed screwdriver or similar shape object may need to be used. This will be done by placing the wedge of the object between the connection of the caster stem and the frame. While applying inward force, pry the caster from the frame. This may require the assistance of a hammer or rubber mallet. Repeat process to all four casters.

5. Upholstered components. - 6min

Seat

On the underside of the seat (upholstered portion), identify and locate the upholstery staples. Using pliers, remove all staples. With the seat cover material now free, separate from the seat. Taking a box cutter knife, or similarly sharp cutter, make an incision around the perimeter of the seat in the foam. *Note: make cuts which yield the largest amount of foam cut.* Once cut, free the foam from the plastic seat part. This may require further cuts to separate foam from the glue adhesion. Separate foam from the plastic seat.

Back

Along the underside of the back, identify the upholstery seam running the length of the back arch. Taking a box cutter knife, or similarly sharp cutter, make an incision from one end to the other following the seam. Once cut fully through, slip the covering material upward from the back. Separate the material from the back. Taking a box cutter knife, or similarly sharp cutter, make an incision around the perimeter of the back in the foam. *Note: make cuts which yield the largest amount of foam cut.* Once cut, free the foam from the plastic seat part. This may require further cuts to separate foam from the glue adhesion. Separate foam from the plastic back.

Visit spec's Environment section at specfurniture.com and click on "Extend your Furniture's Life" for recycling and biodegradation facilities.

Assembly

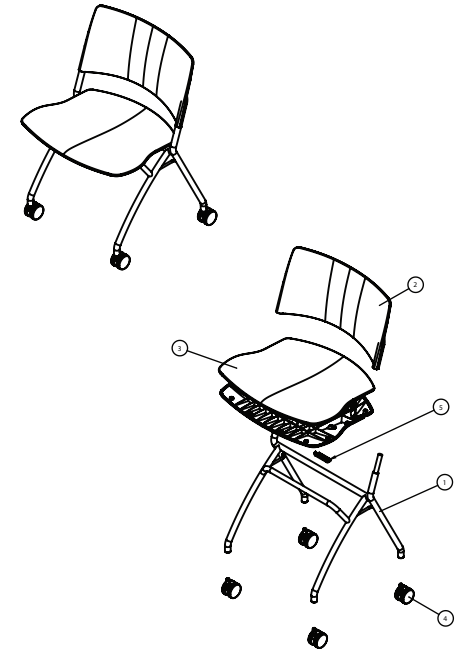

Moled shown: Armless. Casters. No upholstery.